



V-BERETTA M9-RK REPAIR/MAINTENANCE MANUAL

COPYRIGHT

Copyright © 2023 by VirTra Inc. All Rights Reserved. No part of this publication may be reproduced, transcribed, stored in a retrieval system, translated into any language, or transmitted in any form or by any means, electronic, mechanical, magnetic, optical, chemical, photocopying, manual, or otherwise, without prior written permission from VirTra Inc.

VirTra, the VirTra logo are either registered trademarks or trademarks of VirTra in the United States and/or other countries. Product names used in this manual are ascribed to their respective owners and acknowledged.

DISCLAIMER

This manual is intended to be used as a practical and informative guide only and is not to be used as legal authority for any purpose. Specific legal authority comes exclusively from statute and case law. VirTra Inc. shall not be liable for any incidental or consequential damage resulting from the performance or use of this product. In the interest of continued product improvement, we reserve the right to revise, modify or alter the contents of this manual at any time without notice and without obligation to notify any person of such revision or changes.

VirTra disclaims liability for any injury to persons or to property, or other damages of any nature whatsoever, whether special, indirect, consequential, or compensatory, directly or indirectly resulting from the publication, use of, or reliance on this manual. VirTra also makes no guaranty or warranty as to the accuracy or completeness of any information published herein.

CAUTIONS AND WARNINGS

Read, understand, and follow all warnings, training materials, and safety instructions for the Berretta M9.

CAUTION: CLASS **3R** LASER, PRODUCT, LASER RADIATION. DO NOT stare into beam or view directly with optical instruments.

WARNING: V-Beretta M9 Recoil Kits are for training purposes only.

The repair/maintenance procedures described below are to be performed by trained personnel. For installation procedures, please refer to the V-Beretta M9-RK installation manual. Any procedures not covered in either the installation or the repair/maintenance user manuals are considered Factory Maintenance & Repair and it is required that the item be sent to VirTra for repair.

TABLE OF CONTENTS

I. RECOIL KIT COMPONENTS 4

 A. BARREL ASSEMBLY 4

 B. MAGAZINE ASSEMBLY 5

II. INSPECTION/MAINTENANCE GUIDELINES 6

 A. GENERAL CARE 6

 B. LUBRICATION 6

 C. PISTON STRIKER AND O-RINGS 7

 D. AIR TRANSFER TUBE 7

III. TROUBLESHOOTING 8

 A. MAGAZINE LEAKS 8

 B. WEAPON LEAKS 8

 C. SHOT REGISTRATION 9

IV. CONTACT VIRTRA 11

I. RECOIL KIT COMPONENTS

A. BARREL ASSEMBLY

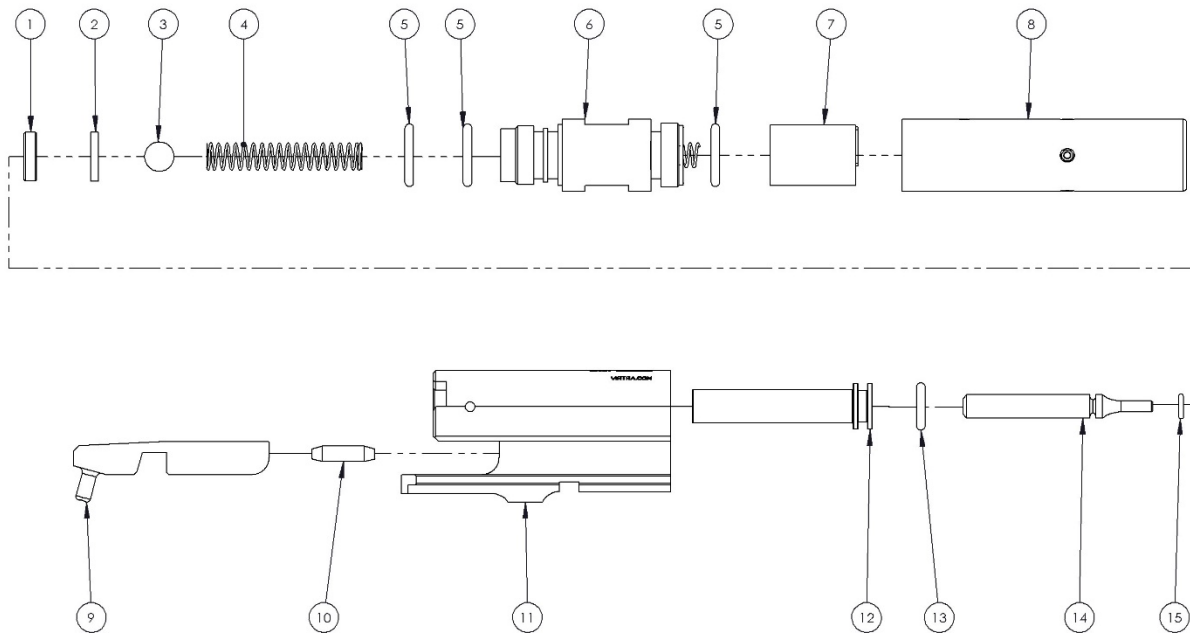

Figure 1: Barrel Assembly

ITEM NO.	DESCRIPTION	ITEM NO.	DESCRIPTION
1	Brass Washer	9	Tailpiece
2	Charge Chamber Seal	10	Tube
3	6mm Ball Bearing	11	Barrel Block
4	Charge Chamber Spring	12	Piston
5	Charge Chamber Outer Seal, 012	13	Piston O-Ring, 010
6	Charge Chamber	14	Striker
7	Battery Pack	15	Striker O-Ring
8	Laser Housing Assembly		

Table 1: Barrel Components

B. MAGAZINE ASSEMBLY

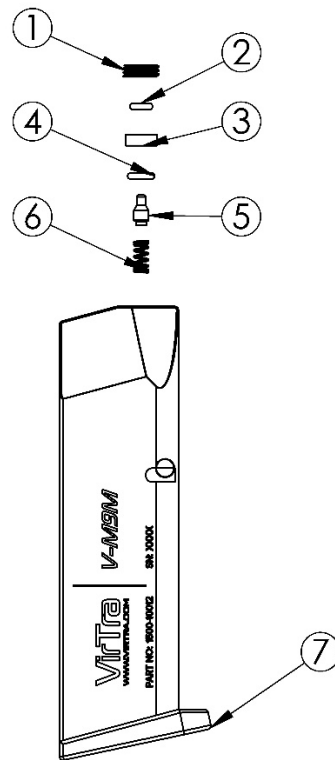

Figure 2: Double Seal Assembly

ITEM NO.	DESCRIPTION
1	Double Seal Cap
2	Top O-Ring, 005
3	Double Seal Spacer
4	Bottom O-ring, 007
5	Double Seal Valve
6	Compression spring
7	Magazine Body

Table 2: Magazine Seal Components

II. INSPECTION/MAINTENANCE GUIDELINES

A. GENERAL CARE

It is recommended that specific (non-duty) firearms and/or firing pins be dedicated for use with the CO2 recoil kits.

All magazines should be depressurized at the end of the day to increase the lifespan of VirTra products. To depressurize a VirTra magazine, first insert the depressurization tool until all CO2 has been expelled. Allow magazine to rest for at least 30 seconds, then insert the tool again to be sure all CO2 has been exhausted.

CO2 recoil kits are capable of expending at least 2 full magazines in less than 60 seconds. Doing so will reduce the temperature of the weapon and cause a reduction in number of shots. If this is experienced, wait a few minutes between magazines.

B. LUBRICATION

The V-Beretta M9 should be checked for lubrication daily. If none is observed, follow these steps to properly lubricate the V-Beretta M9 kit using an approved lubricant (Slip 2000 or Lucas Oil):

- Use a cotton swab or microfiber cloth to apply a thin layer of approved lubricant to the exposed portions of the kit (Figure 3).



Figure 3: Lubrication

- After every use, lubricate the Piston and Striker (Figure 1, #12, #14) through the hole in the side of the Barrel Block (Figure 1, #11) with a small amount of lubricant.

C. PISTON STRIKER AND O-RINGS

This Section details how to inspect the striker and piston O-rings (Figure 1). These O-rings are essential to ensure consistent and high-quality recoil and should be cared for accordingly.

- Disassemble the firearm and remove the barrel assembly.
- Unscrew the charge chamber (Figure 1, #6) from the barrel block (Figure 1, #11) using a ½ inch wrench. Set the charge chamber aside, being careful not to lose or remove any components. Remove both the piston and striker from the Barrel Block (Figure 1, #12, #14, #11) and wipe down with a rag or paper towel.
- Inspect both the piston and striker O-rings (Figure 1, #13, #15) and replace if any damage/wear is present.
- Inspect the striker for any unusual wear or damage. If any is noticed, it should be replaced with a new one supplied by VirTra.
- Use a cotton swab to clean the inside of the piston as well as inside of the barrel block (Figure 1, #12, #11), making sure to remove all buildup or debris.
- Apply a thin layer of lubricant to outside surfaces of both piston and striker O-rings.
- Replace freshly greased piston into the barrel block and move back and forth to distribute grease.

D. AIR TRANSFER TUBE

Inspect the air transfer tube (Figure 1, #10) once a month. If any excessive wear or damage is noticed then it should be replaced. Refer to Figure 4 for an example of a worn air tube.



Figure 4: Damaged Air Tube

III. TROUBLESHOOTING

A. MAGAZINE LEAKS

New magazines may leak at the double seal top cap the first few times they are filled up. If this should happen, insert the magazine into a Beretta M9 weapon that contains a VirTra recoil kit. Fire the weapon in a safe direction a few times and remove the magazine from the weapon. If this leak persists, repeating this process of test firing the weapon may help eliminate the leaking. This can be repeated 2 to 3 times.

If the magazine continues to leak, the seals may need to be greased with lubricant using the following procedures.

Warning: Fully depressurize the magazine before proceeding. Refer to 'General Care' for depressurization procedures.

- Remove the double seal cap (Figure 2, #1) using a thick blade screwdriver.
- Use a small pick or screwdriver to remove the 005 O-ring (Figure 2, #2) and double seal spacer (Figure 2, #3). Inspect the O-ring and replace if any damage/wear is present.
- Use a small pick or screwdriver to remove the 007 O-ring (Figure 2, #4). Inspect the O-ring and replace if any damage/wear is present.
- Invert the magazine and allow the double seal valve (Figure 2, #5) and compression spring (Figure 2, #6) to drop free. Inspect the spring and replace if any damage/wear is present.
- Place compression spring onto the double seal valve and install in the cylinder.
- Apply a thin layer of lubricant to the 007 O-ring and place into the cylinder.
- Apply a thin layer of lubricant to the 005 O-ring, fit into the cup of the double seal spacer, then place into the magazine with O-ring facing up.
- Apply Loctite onto the double seal cap according to VirTra Loctite instructions and install using a thick blade screwdriver. Note: Make sure not to overtighten.

If the leak coming from the double seal of the magazine will not stop after going through the above procedures, or if the leak is coming from a different area such as the bottom of the magazine, fully depressurize the magazine and contact the VirTra Service Department for further assistance.

B. WEAPON LEAKS

If a leak is experienced when the magazine is inserted into the weapon, and the leak is not coming from the magazine, or if it is determined that a leak is occurring within the recoil kit, follow the steps below.

First, refer back to the previous sections associated with the list below to check for possible causes of a leak. Be sure to check all O-rings for excessive wear and check tightness where applicable.

- Section C, Piston Striker and O-Rings
- Section D, Air Transfer Tube

Test the weapon. If the recoil kit is still leaking, use the following steps to disassemble and inspect the charge chamber.

- Disassemble the firearm and remove the barrel assembly.
- Unscrew the charge chamber (Figure 1, #6) from the barrel block (Figure 1, #11) using a ½ inch wrench on the charge chamber and an adjustable wrench on the barrel block.
- Remove the brass washer (Figure 1, #1), charge chamber seal (Figure 1, #2), ball bearing (Figure 1, #3), and charge chamber spring (Figure 1, #4).
- Inspect the charge chamber seal and charge chamber outer seals (Figure 1, #5). Replace the seals if any damage/wear is present.
- Install parts in this order: charge chamber outer seals, charge chamber spring, ball bearing, charge chamber seal, and brass washer. **Installation note:** Ensure the orientation of the charge chamber seal matches its inner chamfered side to the ball bearing and the brass washer inner chamfered side matches the insertion of the striker pin.
- Screw on the charge chamber to the barrel block. Note: Make sure not to overtighten.

If leaks continue after test firing, contact the VirTra Service Department for further assistance.

C. SHOT REGISTRATION

Problems with shot registration can be resolved by the following:

- Ensure that all of the lights are off in the training room while using the simulator. Also make sure that no light from any other source shines on the screens.
- Replace the battery pack in the barrel assembly.
Use a ½ inch wrench to hold the charge chamber (Figure 1, #6) and use your hand to unscrew the Laser Housing (Figure 1, #8). Replace the Battery Pack (Figure 1, #7) and reassemble.
Installation Note: When placing the battery pack in the housing, make sure the polarity is correct by placing the flat part of the battery pack into the housing first (Figure 5).



Figure 5: Battery Installation

- For more comprehensive diagnostic instructions refer to the manual “Establishing and Assigning Weapon Laser ID.” It can be found in the VirTra User Manuals folder on the Instructor Station.
- Another cause of failed shot registration on the system is a poor calibration or change in lighting that requires a calibration of the system. Refer to the V-Tracking™ Calibration Section of the “VOS” Manual. “Establishing and Assigning Weapon Laser ID.” It can be found in the VirTra User Manuals folder on the Instructor Station or on the V-RC Portal

IV. CONTACT VIRTRA

For any questions or additional help with any part of this manual, please contact VirTra via the information below.

VirTra Service Department

VirTra

295 E. Corporate Pl
Chandler, AZ 85225 USA

Office: (480) 508-5977

Email: service@virtra.com

