



# V-GLOCK-RK REPAIR/MAINTENANCE MANUAL

---

## **COPYRIGHT / TRADEMARKS**

No part of this publication may be reproduced, transcribed, stored in a retrieval system, translated into any language, or transmitted in any form or by any means, electronic, mechanical, magnetic, optical, chemical, photocopying, manual, or otherwise, without prior written permission from VirTra Inc. Product names used in this manual are ascribed to their respective owners and acknowledged.

## **DISCLAIMER**

This manual is intended to be used as a practical and informative guide only and is not to be used as legal authority for any purpose. Specific legal authority comes exclusively from statute and case law. VirTra Inc. shall not be liable for any incidental or consequential damage resulting from the performance or use of this product. In the interest of continued product improvement, we reserve the right to revise, modify or alter the contents of this manual at any time without notice and without obligation to notify any person of such revision or changes.

VirTra disclaims liability for any injury to persons or to property, or other damages of any nature whatsoever, whether special, indirect, consequential or compensatory, directly or indirectly resulting from the publication, use of, or reliance on this manual. VirTra also makes no guaranty or warranty as to the accuracy or completeness of any information published herein.

## **CAUTIONS AND WARNINGS**

Read, understand and follow all warnings, training materials, and safety instructions for the Glock.

**CAUTION:** CLASS **3R** LASER, PRODUCT, LASER RADIATION. DO NOT stare into beam or view directly with optical instruments.

**WARNING:** VirTra Glock recoil kits are for training purposes only.

The repair/maintenance procedures described below are to be performed by trained personnel. For installation procedures, please refer to the V-GLOCK-RK installation manual. Any procedures not covered in either the installation or the repair/maintenance user manuals are considered Factory Maintenance & Repair and it is required that the item be sent to VirTra for repair.

**TABLE OF CONTENTS**

I. RECOIL KIT COMPONENTS ..... 4

    A. BARREL ASSEMBLY ..... 4

    B. MAGAZINE ASSEMBLY ..... 5

II. INSPECTION/MAINTENANCE GUIDELINES ..... 6

    A. GENERAL CARE ..... 6

    B. LUBRICATION ..... 6

    C. TAILPIECE ..... 7

    D. PISTON STRIKER AND ASSOCIATED O-RINGS ..... 8

    E. AIR TRANSFER TUBE ..... 9

III. TROUBLESHOOTING ..... 10

    A. MAGAZINE LEAKS ..... 10

    B. WEAPON LEAKS ..... 10

    C. SHOT REGISTRATION ..... 11

IV. CONTACT VIRTRA ..... 13

# I. RECOIL KIT COMPONENTS

## A. BARREL ASSEMBLY

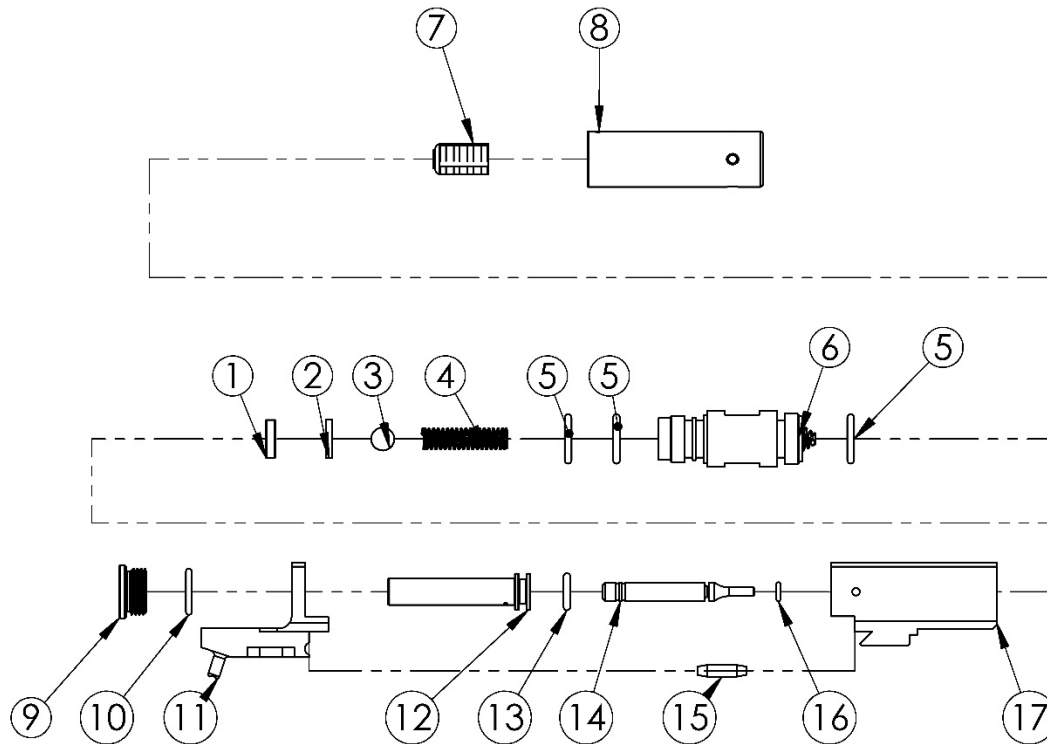

Figure 1: Barrel Assembly

ITEM NO.	DESCRIPTION	ITEM NO.	DESCRIPTION
1	Brass Washer	10	Tailpiece Fastener Seal
2	Charge Chamber Seal	11	Tailpiece
3	6mm Ball Bearing	12	Piston
4	Charge Chamber Spring	13	Piston O-Ring, 010
5	Charge Chamber Outer Seal, 012	14	Striker
6	Charge Chamber	15	Air Transfer Tube
7	Battery Pack	16	Striker O-Ring
8	Laser Housing Assembly	17	Barrel Block
9	Tailpiece Fastener		

Table 1: Barrel Assembly Components

**B. MAGAZINE ASSEMBLY**

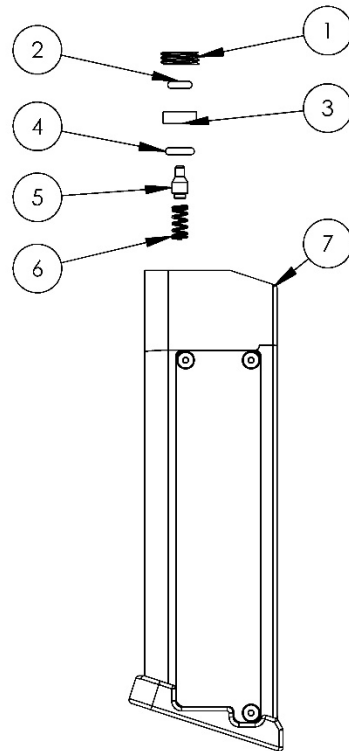

Figure 2: Double Seal Assembly

ITEM NO.	DESCRIPTION
1	Double Seal Cap
2	Top O-Ring, 005
3	Double Seal Spacer
4	Bottom O-ring, 007
5	Double Seal Valve
6	Compression spring
7	CO2 Magazine

Table 2: Double Seal Components

## II. INSPECTION/MAINTENANCE GUIDELINES

### A. GENERAL CARE

It is recommended that specific (non-duty) firearms and/or firing pins be dedicated for use with the CO2 recoil kits.

All CO2 magazines should be depressurized at the end of the day to increase the lifespan of VirTra products. To depressurize a VirTra magazine, first insert the depressurization tool until all CO2 has been expelled. Allow magazine to rest for at least 30 seconds, then insert the tool again to be sure all CO2 has been exhausted.

CO2 recoil kits are capable of expending at least 2 full magazines in less than 60 seconds. Doing so will reduce the temperature of the weapon and cause a reduction in number of shots. If this is experienced, wait a few minutes between magazines.

### B. LUBRICATION

The V-GLOCK-RK should be checked for lubrication daily. If none is observed, follow these steps to properly lubricate the V-GLOCK Recoil Kit using an approved lubricant from the list supplied in the V-Glock-RK Installation Manual.

- Pull the slide all the way to the rear and lock back using the slide lock.
- Use a cotton swab or microfiber cloth to apply a thin layer of approved lubricant to the exposed portion of the kit sticking out of the front of the slide (Figure 3).



Figure 3: Ejection Port and Barrel Lubrication

- Pull the slide back just slightly and pull down the take down bar on both sides. Push forward to take the slide off. Apply a thin layer of approved lubricant to the 4 metal rails.



Figure 4: Tail Lubrication

- Do not use any of the approved lubricants on the internal components of the recoil kit. Internal components such as the piston striker and O-rings (Figure 1) should be lubricated with MAGNALUBE®-G TEFLON®GREASE #MGL-4.

### **C. TAILPIECE**

Before beginning training, always ensure the tailpiece fastener is secured tightly and the tailpiece is in place.

- Pull the slide towards the rear of the gun, exposing about an inch of the chamber (Figure 5).



Figure 5: Tailpiece Tightening

- Insert the tailpiece wrench into the mating holes on the tailpiece fastener (Figure 5).
- Turn wrench in a clockwise direction until tailpiece fastener is completely snug and cannot turn anymore.

Make sure the tailpiece and barrel block edges line up correctly. Misalignment can cause premature wear on the air transfer tube and possible kit malfunction (Figure 1, 15).

- Once a week remove the Tailpiece Fastener and inspect the Tailpiece Fastener seal (Figure 1, #10). Replace if damaged.

#### **D. PISTON STRIKER AND ASSOCIATED O-RINGS**

Inspection of the striker and piston O-rings (Figure 1) should be done once a week. These O-rings are essential to ensure consistent and high quality recoil and should be cared for accordingly.

- Disassemble the firearm and remove the barrel assembly.
- Remove both the piston and striker (Figure 1, #12, #14) and wipe down with a rag or paper towel.
- Inspect both the piston and striker O-rings (Figure 1, #13, #16) and replace if any damage/wear is present.
- Inspect the striker pin for any unusual wear or damage. If any is noticed, it should be replaced with a new one supplied by VirTra.
- Use a cotton swab to clean the inside of the piston as well as inside of the barrel block, making sure to remove all buildup or debris.
- Apply a thin layer of MAGNALUBE®-G TEFLON®GREASE #MGL-4 to outside surfaces of both O-rings.



- Replace freshly greased piston into the barrel block and move piston back and forth to distribute grease (Figure 6).



Figure 6: Piston Lubrication

- Inspect the tailpiece and tailpiece fastener to ensure no large chips or breaks have occurred in any of the parts. If damage is noticed in either part, the kit should not be used.

#### **E. AIR TRANSFER TUBE**

Inspect the air transfer tube (Figure 1, #15) once a month. If any excessive wear or damage is noticed then it should be replaced. Refer to the picture below of a worn air transfer tube.



Figure 7: Damaged Air Tube

### III. TROUBLESHOOTING

#### A. MAGAZINE LEAKS

New magazines may leak at the double seal top cap the first few times they are filled up. If this should happen, insert the magazine into a Glock weapon that contains a VirTra recoil kit. Fire the weapon in a safe direction a few times and remove the magazine from the weapon. If this leak persists, repeating this process of test firing the weapon may help eliminate the leaking. This can be repeated 2 to 3 times.

If the magazine continues to leak, the seals may need to be greased with MAGNALUBE®-G TEFLON®GREASE #MGL-4 using the following procedures.

- **Warning:** If using a CO2 kit, fully depressurize the magazine before proceeding. Refer to 'General Care' for depressurization procedures. If using a High Pressure Air kit, be sure to disconnect the quick release at the bottom of the magazine.
- Remove the double seal cap (Figure 2, #1) using a thick blade screwdriver.
- Use a small pick or screwdriver to remove the 005 O-ring (Figure 2, #2) and double seal spacer (Figure 2, #3). Inspect the O-ring and replace if any damage/wear is present.
- Use a small pick or screwdriver to remove the 007 O-ring (Figure 2, #4). Inspect the O-ring and replace if any damage/wear is present.
- Invert the magazine and allow the double seal valve (Figure 2, #5) and compression spring (Figure 2, #6) to drop free. Inspect the spring and replace if any damage/wear is present.
- Place compression spring onto the double seal valve and install in the cylinder.
- Apply a thin layer of MAGNALUBE®-G TEFLON®GREASE #MGL-4 to the 007 O-ring and place into the cylinder.
- Apply a thin layer of MAGNALUBE®-G TEFLON®GREASE #MGL-4 to the 005 O-ring, fit into the cup of the double seal spacer, then place into the magazine with O-ring facing up.
- Apply Loctite onto the double seal cap according to VirTra Loctite instructions and install using a thick blade screwdriver. Note: Make sure not to overtighten.

If the leak coming from the double seal of the magazine will not stop after going through the above procedures, or if the leak is coming from a different area such as the bottom of the magazine, fully depressurize the magazine and contact the VirTra Service Department for further assistance.

#### B. WEAPON LEAKS

If a leak is experienced when the magazine is inserted into the weapon, and the leak is not coming from the magazine, or if it is determined that a leak is occurring within the recoil kit, follow the steps below.

First, refer back to the previous sections associated with the list below to check for possible causes of a leak. Be sure to check all O-rings for excessive wear and check tightness where applicable.

- Section C, Tailpiece
- Section D, Piston Striker and Associated O-Rings

- Section E, Air Transfer Tube

Test the weapon. If the recoil kit is still leaking, use the following steps to disassemble and inspect the charge chamber.

- Disassemble the firearm and remove the barrel assembly.
- Unscrew the charge chamber (Figure 1, #6) from the barrel block (Figure 1, #17) using a ½ inch wrench on the charge chamber and an adjustable wrench on the barrel block.
- Remove the brass washer (Figure 1, #1), charge chamber seal (Figure 1, #2), ball bearing (Figure 1, #3), and charge chamber spring (Figure 1, #4).
- Inspect the charge chamber seal and charge chamber outer seals (Figure 1, #5). Replace the seals if any damage/wear is present.
- Install parts in this order: charge chamber outer seals, charge chamber spring, ball bearing, charge chamber seal, and brass washer. **Installation note:** Ensure the orientation of the charge chamber seal matches its inner chamfered side to the ball bearing and the brass washer inner chamfered side matches the insertion of the striker pin.
- Screw on the charge chamber to the barrel block. Note: Make sure not to overtighten.

If leaks continue after test firing, contact the VirTra Service Department for further assistance.

### **C. SHOT REGISTRATION**

Problems with shot registration can be resolved by the following:

- Ensure that all of the lights are off in the training room while using the simulator. Also make sure that no light from any other source shines on the screens.
- Replace the battery pack in the barrel assembly.  
Use a ½ inch wrench to hold the charge chamber (Figure 1, #6) and use your hand to unscrew the Laser Housing (Figure 1, #8). Replace the Battery Pack (Figure 1, #7) and reassemble.  
**Installation Note:** When placing the battery pack in the housing, make sure the polarity is correct by placing the flat part of the battery pack into the housing first (Figure 8).



*Figure 8: Battery Installation*

- For more comprehensive diagnostic instructions refer to the manual “Establishing and Assigning Weapon Laser ID”. It can be found in the VirTra User Manuals folder on the Instructor Station.
- Another cause of failed shot registration on the system is a poor calibration or change in lighting that requires a calibration of the system. Refer to the V-Tracking™ Calibration Section of the VOS™ Manual. “Establishing and Assigning Weapon Laser ID.” It can be found in the VirTra User Manuals folder on the Instructor Station or in the V-RC Portal.

#### **IV. CONTACT VIRTRA**

For any questions or additional help with any part of this manual, please contact VirTra via the information below.

VirTra Service Department



295 E. Corporate Pl  
Chandler, AZ 85225 USA

Phone: 480.968.1488, Option 8  
Email: [service@virtra.com](mailto:service@virtra.com)